



Method Statement

Ref. #: DCP08/07-0011-A-2023



Flexseal PU440

(One component, non-sage, elastomeric polyurethane sealant with high tear and weather resistance)



Table of Content

SECTION A: GENERAL COMMENTS	3
General Notes	3
High-Temperature Working	3
Low-Temperature Working	3
System Products	3
Tools and Equipment	4
SECTION B: APPLICATION	5
Substrate and Joint Preparation	5
Priming	5
Joint Preparation	6
Application	6
Tooling and Finishing	7
On-Site Verification Testing	8
Cleaning	8
Limitations	8
SECTION C: CAUTIONS	9
Health & Safety	9
SECTION D: APPROVAL AND VARIATIONS	9



Section A: General Comments

General Notes:

The information below is a detailed overview of the application of **Flexseal PU440** sealant system and should be read in conjunction with the relevant technical data sheet prior to application. All DCP Products should be applied by experienced specialist contractors.

All the points below assume the correct preparation of the relevant surface.

*Note: This guideline is written specifically for **Flexseal PU440**.*

High-Temperature Working:

Application temperature ranges from 5°C - 35°C. However, it is suggested that, for temperatures above 35°C, the following guidelines are adopted as good working practice:

- i. Unmixed materials and equipment should be stored in a cool shaded area and away from direct sunlight.
- ii. Avoid application during peak temperature of the day.
- iii. Plan for enough materials, tools, and labor to ensure a continuous applicant process.

Low-Temperature Working:

It is suggested that, for temperatures below 10°C, the following guidelines are adopted as good working practice:

- i. Unmixed materials should be stored in a warm.
- ii. Substrate's temperature must be at least 3°C above measured dew point temperatures if any.
- iii. Do not apply under rain or snow, and avoid dew points conditions during application.
- iv. Avoid applying the grout if the temperature is around 5°C and falling.

System Products:

Primer [If required]: **Flexprime PS100**.

Sealant: **Flexseal PU440**.

Backing Rod: **Cellrod**.

Tools and Equipment:

It is suggested that the following list of equipment are adopted as a minimum requirement

Personal protection

- : Protective overalls
- : Goggles or a face mask
- : Good quality gloves
- : Safety shoes
- : Safety helmet



Equipment

- : Stiff wire brush (Fig.1)
- : Soft brush (Fig.2)
- : Air compressor (Fig.3)
- : Sealant barrel gun (Fig.4)
- : Backing rod (Fig.5)
- : Masking tape (Fig.6)



Fig.1: Stiff wire brush



Fig.2: Soft brush



Fig.3: Air compressor



Fig.4: Sealant barrel gun



Fig.5: Backing rod



Fig.6: Masking tape

Section B: Application

Please note that the quality and durability of an adhesive bond or seal are determined by using the correct product and joint design. While the most critical steps are proper surface preparation and an appropriate application.

1.0 Substrate and Joint Preparation

- 1.1 All joints to be sealed must be clean, dry, and free from any laitance, wax, grease, dirt, oil, or any contaminations such as release agents, curing compounds, dust, dirt, cavities, projecting nibs, etc.
- 1.2 Contamination of substrates by silicone or silicone oil will inhibit polyurethanes from adhering to substrates.
- 1.3 Excess laitance, old coating, or surface treatments are best removed by mechanical grinding, light sand/grit blasting followed by vacuum cleaning to remove dust debris. All preparation equipment should be of a type approved by DCP.
- 1.4 If the substrates need to be cleaned, use methyl ethyl ketone (MEK), acetone, or grease remover.
- 1.5 Always be sure that the substrates are dry before the application.

2.0 Priming

- 2.1 Priming does no substitute for good preparation. No primer is required for most clean and dry substrates.
- 2.2 **Flexseal PU440** generally has strong adhesion to common clean, dry and sound substrates without primers. However, **Flexprime PS100** can be used on porous substrates, horizontal substrates or substrates which will be continuously submerged in water in order to enhance the adhesion, achieve optimum bond strength and reduce the risk of failure.



Flexprime PS100 method of application:

- Stir individual components of **Flexprime PS100** and ensure that bottom and sides are thoroughly scraped.
- Transfer the entire content of hardener into the base and mix for 2 - 3 minutes using slow speed mixer fitted with suitable paddle.
- Apply one thin coat of the mixed primer using a brush for application to the prepared surface.

Note: avoid any primer ponding on the substrate.

- Apply **Flexseal PU440** within 10 - 30 minutes from the application of **Flexprime PS100** at 23°C.
- 2.3 Contact DCP's Technical Department for more information about the application on specific substrates.

3.0 Joint Preparation

- 3.1 **Cellrod** which is a closed-cell polyethylene backer rod should be used to provide the correct joint depth and support the applied sealant.
- 3.2 To ensure that the rod will be able to withstand the sealant; the **Cellrod** size shall be 25% larger in diameter than the joint width, this will also insure it is held in position in a secure fit and the joint width/depth ratio is maintained.
- 3.3 **Cellrod** will also ensure intimating contact of sealant with joint walls when tooling.
- 3.4 Care must be taken not to puncture the backing rod while installing it in place prior to sealant installation, as it may cause bubbling in the sealant.

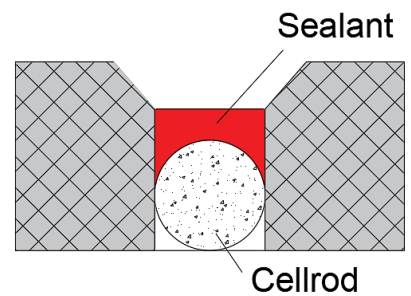

For proper joint depth selection, the following guidelines should be followed:

- If the joint width < 10 mm, then the Joint depth = Joint Width
- If the joint width is 10 – 20 mm, then the joint depth = 10 mm.
- If the joint width > 20 mm, then the Joint Depth = ½ Joint width

Note: Minimum sealant depth should however be 5 mm.

- 3.5 Immediately Apply masking tape on each side of the joint to maintain a clean finish.



Notes:

- *Check the substrate in advance. Ensure that the substrate is clean, dry, and in good condition.*
- *Proper preparation will eliminate the majority of installation failures.*
- *Most common mode of sealant failure is adhesive.*

4.0 Application

4.1 For Cartridge

- 4.1.1 Cut the tip from the cartridge above the screw thread, remove the nozzle cap and then trim the nozzle diagonally to fit the joint width.
- 4.1.2. Finally, screw the nozzle onto the cartridge.
- 4.1.2 Place **Flexseal PU440** cartridge into the cartridge gun.
- 4.1.3 Press the tip of the gun firmly towards the point of application and pull the trigger to release the sealant.

4.2 For Sausages

- 4.2.1 Unscrew the Sausages gun end cap and fix the nozzle into the cap.
- 4.2.2 Place **Flexseal PU440** sausage inside the gun barrel.
- 4.2.3 Use a pair of scissors or secateurs to cut off the clip off the sausage while still in the gun.
- 4.2.4 Replace the end cap with nozzle attached on the gun barrel.
- 4.2.5 Use a pair of scissors or secateurs to cut the gun nozzle diagonally to fit the joint width.
- 4.2.6 Extrude **Flexseal PU440** by squeezing the large trigger.
- 4.2.7 To replace the sausage, simply unscrew the end cap, dispose of the used pack and load in the new sausage.

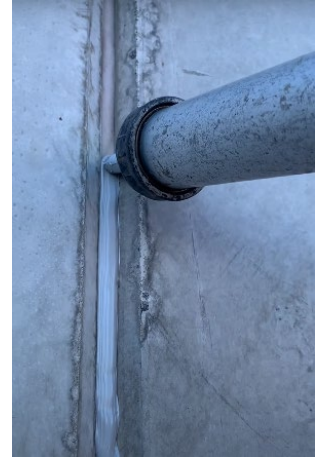

- 4.3 Extrude and dispense firmly into the joint while ensuring complete contact between the applied sealant and joint walls.
- 4.4 Maintain a steady flow of sealant to avoid air entrapment, and avoid overlapping the sealant.

Consumption in joints:

(Linear meter per 600 cc sausage)

Width Depth	5 mm	10 mm	15 mm	20 mm	25 mm	35 mm
5 mm	24	12				
7.5 mm			5.3	4.0		
10 mm				3.0	2.4	
15 mm					1.6	1.1

5.0 Tooling and Finishing

- 5.1 Apply uniform pressure and tool the sealant for the desired shape using clean, freshly polished stainless steel or plastic tool such as (spatula, spoon, or metal piece), appropriate tooling liquid may be used during the tooling process.

Notes:

- *Tooling products such as solvents, concentrated detergents or other cleaners may cause tacky surfaces or accelerated aging of the smoothed surface.*
- *Never use alcohol or other solvents to tool a polyurethane sealant.*



- 5.2 Only tool once and never tool in more than one direction.
- 5.3 The sealant should be tooled to a shape to actively shed water and prevent the ponding of water on the surface of the joint.
- 5.4 Tooling and finishing should be carried out immediately after the application of the sealant within the skin time of the sealant to allow for optimum workability.
- 5.5 Tooling the sealant will ensure complete contact with the surface.
- 5.6 Remove the masking tape directly after tooling the sealant.
- 5.7 The applied sealant bead must be left undisturbed until it has sufficiently cured.



6.0 On-Site Verification Testing (On-Site Pull Test)

This verification test is to be done if needed after the material has fully cured, to ensure a proper bond.

- 6.1 Place sealant and allow to cure.
- 6.2 Cut through the sealant across the width of the sealant joint from one substrate to the other.
- 6.3 Make two cuts starting at the previous cut approximately 7.5 cm long, at both sides of the joint along the substrate/sealant interface.
- 6.4 Grasp the cut piece of sealant firmly 2.5 cm from its bonded edge and slowly pull at a 90 degree angle from the substrate.
- 6.5 The sealant should not peel from the joint interface.
- 6.6 Inspect the type of failure that occurs upon full extension to failure and the degree of force required (little or much); If the substrate adhesion is acceptable, the sealant should tear cohesively within itself or elongate to an extension value beyond the sealant's movement capability before failing adhesively.
- 6.7 Repair the joint area that was tested by re-applying new sealant to the area.

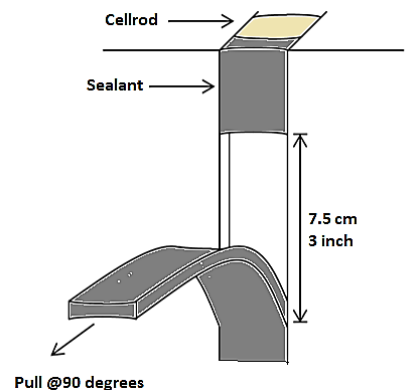

7.0 Cleaning

- 7.1 All tools should be cleaned **immediately** after finishing using paper towels and then wipe by using Acetone, xylene, or other suitable solvents.

8.0 Limitations

- 8.1 The recommended application temperature range is between 5°C and 35°C.
- 8.2 For cold weather, store **Flexseal PU440** in a heated area at 20°C for 24 hours.
- 8.3 Tooling can only be accomplished prior to the sealant achieving a skinned surface; once the sealant has begun to form a skinned surface, the joint can no longer be effectively tooled.
- 8.4 Although **Flexseal PU440** is generally paintable, it is advisable to test the specific paint for compatibility.
- 8.5 Long exposure to UV, will reduce surface gloss, but will not affect sealant performance.
- 8.6 **Flexseal PU440** is not recommended for unsound substrates.



Section C : Cautions

Health and safety

Avoid **Flexseal PU440** contact with skin or eyes. In case of accidental contact with eyes, immediately flush with plenty of water for at least 10 minutes and seek medical advice if necessary.

Fire:

Flexseal PU440 is nonflammable.

For further information on refer to the Material Safety Data Sheet.

Section D : Approval and Variations

This method statement is offered by DCP as a 'standard proposal' for the application of **Flexseal PU440**. It remains the responsibility of the Engineer to determine the correct method for any given application. Where alternative methods are to be used, these must be submitted to DCP for approval, in writing, prior to commencement of any work. DCP will not accept responsibility or liability for variations to the above method statement under any other condition.